

# The HIGH SPEED *EAGLE V5* (Graphite Version)

New Design - Innovative Technology - High Performance

*HIGH SPEED*  
**EAGLE V5**  
New 3/5-Axis Design



Compact 3/5-Axis Solution!

Machine Footprint: W x D x H  
79.3 x 108.0 x 96.0 inch

Axis Travel: X x Y x Z  
21.6 x 15.7 x 15.7 inch

Optional 3-Axis Table Size:  
X 21.6 x Y 15.7 inch

Standard Rotary Table Size/Tilt:  
15.7" Dia / -120 ~ +60 Deg.

## Features:

- **Polymer Concrete Base-Design** and topology optimized structure for optimal stiffness, temperature symmetry and vibration-damping machine bed with a 3-point foundation set-up.
- **Active Thermal Control** uses a system of active cooling lines running throughout the machine structure where ever heat is generated such as, the machine base, spindle mounts, floating and fixed bearings, guide ways, etc. to maintain the highest possible machining accuracy.
- **Direct Coupled AC Servo Motors** provide rapid speeds of 1181"/min. with 590"/sec<sup>2</sup> acceleration, uses Heidenhain glass scales in all axes to maintain the highest accuracy possible.
- **Direct Drive C- Axis** is capable of turning 360° @ 60 RPM while the High Dynamic tilting B- Axis is capable of holding a 15.7" diameter @ 550 lb. with a -120° ~ +60° tilting angles @ 25 RPM.
- **Standard Spindle Size** is a 42,000 RPM HSK-E40 spindle providing 20 HP w 4.4 ft. lb. of torque to best fit the applications this machine is designed for.
- **Heidenhain 3/5-Axis Control** the TNC 640 with 15" display provides a 0.5ms (120,000 BPM) processing speed with a 5000 block look ahead and a premium software package to produce the smoothest 3D profiles.



# Gantry Design supports the X, Y and Z-Axis

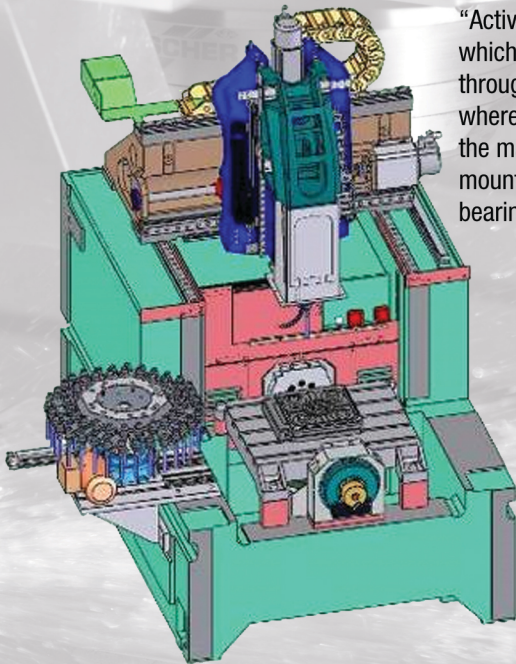

Precision Package-5 includes "Active Temperature Control" which uses active cooling lines throughout the machine structure where ever heat is generated, the machine base, spindle mounts floating bearings, fixed bearings, guide ways, etc.

This drawing is showing the optional 3-axis table mounted over the standard rotary table.

Polymer Concrete is used for best vibration damping and higher weight, therefore optimum behavior between moving and static mass.

**Standard**  
**4th/5th Axis Unit**  
 Accepts 15.7" sq. pallets for automation that can load from the right side of the machine.



**V5 Graphite Version**  
 Units: mm [inch]

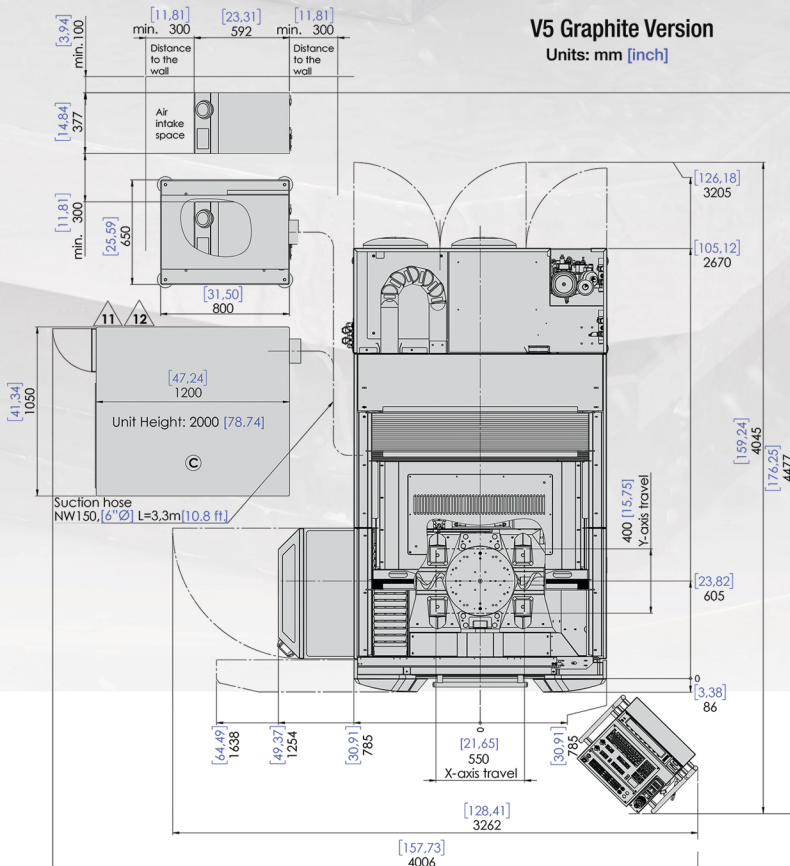

## V5 Graphite Version Technical Data

Travel distances	X 21.6" x Y 15.7" x Z 15.7" X 550 mm x Y 400 mm x Z 400 mm
Travel speed	max. 1,181"/min. : 30 m/min
Acceleration	max. 590.5"/s <sup>2</sup> : 15 m/s <sup>2</sup>
3-Axis T-slot table (option)	T-slot table expandable over 4 <sup>th</sup> /5 <sup>th</sup> axis
3-Axis Table clamping surface	X 25.6" x Y 19.7" : X 650 mm x Y 500 mm
Max. 3-Axis table load capacity	up to 1102 lb. : 500 kg
T-slot	5 x 14 H12
Spindle nose to table distance min./max.	2.0"/ 17.7" 50/450 mm
Workpiece size 3-Axis	X 21.6" x Y 15.7" x Z 15.7" (max. 1,102 lb) X 550 x Y 400 x Z 400 mm (max. 500 kg)
Workpiece size 5-Axis	Ø 15.7" ; H 15.0" (max. 440 lb) Ø 400 mm; H 380 mm (max. 200 kg)
Connected load	36 kVA
High-frequency spindle Standard Optional Spindle	HSK E40: 1 - 42,000 rpm HSK E50: 1 - 36,000 rpm
High-frequency spindle power Spindle power Optional	20 HP : 15 kW 33.2 HP : 24.8 kW
Tool changer selection Std./Opt.	32/100 pos. (HSK E40) 32/80 pos. (HSK E50)
Minimum lubrication	Included
CNC control unit	Heidenhain TNC 640 with 15" Screen
Dimensions	W 79.5" x D 110.2" x H 96.5" W 2.020 mm x D 2.800 x H 2.450 mm
Total weight	15,873 lb. : 7.200 kg
Gear Drive B-Axis w Direct Drive C-Axis rotary table	B-axis -120° / +60° @ 25 rpm C-axis 360° @ 60 rpm Workpiece weight: 550 lb. : 250 kg

MMS Dust Collection by KELLER

Blower: 116 cu.ft./hr.  
 Air volume: 70 cu.ft./hr.  
 Filter surface: 3 pc. @ 110 sq.ft. each  
 Motor power: 4.4 Hp  
 Sound level: 75dB (A)  
 Unit weight: 1,212 lb.

## Workpiece Dimensions

### 3-AXIS

optional table

XxYxZ: 21.6" x 15.7" x 15.7"  
 550 x 400 x 400 mm  
 max. 1102 lb : 500 kg,

### 5-AXIS

Ø 15.7" : 400 mm / H 15.0" : 380 mm  
 max. weight: 550 lb. : 250 kg

**MC MACHINERY SYSTEMS, INC.**

a subsidiary of Mitsubishi Corporation

MC Machinery Systems Inc.  
 85 NorthWest Point Blvd.  
 Elk Grove Village, IL. 60007  
 Phone: (630) 616-5920  
 Fax: (630) 616-4068  
 www.mcmachinery.com